



Features

- Single Chip CANopen Controller for joystick applications
- Up to 4 axis
- Memory function:
Freezing of axis position on keystroke
- According to CiA Draft Standards
DS301 Version 4.0
DS401 Version 2.0 with joystick extension
- CAN baud rate up to 1MBit
- Detection of broken potentiometer cables
- Emergency interrupt input
- General purpose I/O pins with 4mA
- Watchdog output
- Temperature ranges up to -40 to 105 °C
- Package QFP64

General Description

The CO4013 is a low cost, high performance Single Chip solution for CANopen compatible Joysticks with potentiometers. The device offers the complex implementation of the CANopen standards DS301 and DS401 with joystick extension in a single chip.

CO4013 provides control for up to 4 axis. The joysticks axis position is sampled with a resolution of 10 bits. There are 20 digital input lines and 4 digital output lines. All input lines have internal debounce logic with programmable debounce times. Internal axis position memory function is provided for all axis. To support push buttons as well as switches, there are optional flip-flops implemented.

The CO4013 offers zero position detection for each axis. This feature enables detection of broken cable connections to the joystick potentiometers. An additional emergency interrupt input pin is also provided.

The CO4013 Chip requires only few external components, just like a crystal, a CAN transceiver and capacitors. To minimize external interface recommendations all output pins have high current drive capability of 4 mA. For interfacing opto isolators no external drivers are required.

CO4013 is a software solution to run on Fujitsu MB90F497 micro controller. It is offered either as software runtime licence or as ready-programmed chip (runtime licence included).

Customer specific versions are available on request.

CANopen Features

- 2 Transmit- and 1 Receive PDOs
- Dynamic PDO mapping
- Variable PDO identifier
- All CANopen specific PDO transmission types supported:
synchronous, asynchronous, event driven, cyclic, acyclic and remote frame dependent.
- Event timer and inhibit timer features for all transmit PDOs.
- Node guarding, Life guarding, Heartbeat
- Variable SYNC identifier
- Emergency messages
- Minimum boot up

Ordering Information

CO4013 Chip (programmed, licence included)

| Part | Temp. Range | Package |
|-------------|------------------|---------|
| CO4013A-FL | -40 °C to 85 °C | QFP64 |
| CO4013AE-FL | -40 °C to 105 °C | QFP64 |

Software licence

| Part | Description |
|-------------|--|
| CO4013SRL-F | Software runtime licence for Fujitsu MB90F497 controller |

Boards with CO4013 (licence included)

| Part | Description |
|------------|--|
| CO4013-EVA | Evaluation board |
| JOBO4013 | Full feature 4 Axis Joystick board for application |

Pin Description

All input / output pins are high impedance during reset. The CO4013 does not support internal pull up/down resistors. Use external components where needed. All input pins have Schmitt trigger characteristics. See chapter "Typical Applications" for additional information.

X-IN .. W-IN: Analog Axis Position Input pins

Analog Input pins for axis X .. W. The axis position is a 10 bit analog value converted into a signed integer value. The axis zero position must give an input voltage of 2.5V (at 5V analog reference voltage AVREF).

To disable an axis the corresponding axis position input pin must be connected to pin CFG0/LED (pin 14 of the CO4013).

Note: *The enabled axis must be in an ascending order. Do not disable an axis, if you want to use another axis with higher number. Disabling of an axis will cause disable of all axis with higher numbers automatically. (X=1, Y=2, Z=3, W=4) For example, if you disable axis 3 (pin Z-IN is connected to pin CFG0/LED), axis 4 (W-IN) will be disabled by default.*

X-0POS .. W-0POS:

Analog Axis Zero Position Input pins

Analog Zero position Input pins for axis X .. W. Connect these pins to the midpoint taps of the axis potentiometers in order to enable the broken cable detection. If the axis potentiometers do not support a midpoint tap, or if broken cable detection is not wanted, supply a voltage conforming the midpoint tap to these pins.

X..W-NEGATIVE / X..W-POSITIVE

Digital input pins for direction switches. There is no specific function added to this pins, so they might be used as general purpose input lines.

RECOMANDED: By using this inputs as direction indications you should use the following definition: POSITIVE means, the analog value of the axis (moving direction positive) is greater then the value of zero position. NEGATIVE means, the analog value of the axis (moving direction negative) is less then the value of zero position. At Zero position both inputs must be not active.

X-MEM .. W-MEM: Memory function

The DS401 joystick extension describes a memory function for each axis. If this memory function is started, the value of the corresponding axis is fixed, until the memory function is released again.

The memory input pins of the CO4013 activate this feature. The input pins (active Low) may be driven either by bistable switches or push buttons. In case of push buttons, a memory function flip-flop will be activated with the first low pulse will start; the next pulse will release the memory function.

The memory function can be configured only to sample the memory input pins. In this case the analog value of axis position input will not be frozen. Otherwise the memory function can use an internal analog axis input freezing feature. In this case, the analog value representing the joystick position will be fixed until the memory function is released.

See "Operation Mode: Memory Function" for more information.

OUT0 .. OUT3

If push buttons are selected for memory function, the state of the output lines OUT0 to OUT3 (active low) represent the state of the internal memory function flip-flop:

OUTx = low memory function flip-flop is set.
OUTx = high memory function flip-flop is not set.

The output pins should be used for LEDs.

If push switches are selected for memory function, the output pins OUT0 to OUT3 are general-purpose output pins, with an own receive PDO.

IN0 to IN7: General purpose digital input pins

General-purpose input pins. Use this pins for additional keys on your joystick.

CF: Filter Capacitor input

For correct operation of the CO4013 a ceramic capacitor of 100 nF or 220 nF must be connected between Pin 57 (CF) and VSS. Place this component as close as possible to the CO4013.

X0, X1: Crystal oscillator input

Connect a crystal of 4 MHz between X0 and X1. Use additional ceramic capacitors of 22 pF between X0 and X1 to VSS.

TEST: Reserved pin

Leave pin TEST unconnected.

ZPEIRQ#: Zero-Position Interrupt

This active low input pin is provided to support an additional emergency. If the CO4013 scans a low level on pin ZPEIRQ#, the device automatic enters the error state given in Object 67FE.02 (default enter preoperational state).

Further more the Error Register (index 1001) is set to 0x01, indicating a device error.

Last but not least the device will send an emergency telegram with error code 0x3120 indicating an "Input voltage to low" error.

If this interrupt is not to be used in your application, make sure, that pin ZPEIRQ# is forced to logic high level.

VCC, AVCC, VSS, AVSS, AVREF: Power Supply

VCC, VSS: Digital Supply
 AVCC, AVSS: Analog Supply for axis position input measurement
 recommended: AVCC = VCC
 AVSS = VSS;
 AVREF: Reference Voltage for for axis position input measurement
 recommended: AVREF = AVCC

Make sure that all ground and power supply pins are connected. Do not leave any ground or power supply pins open. Connect decoupling capacitors as close as possible to the device. See chapter "Recommended Operation Conditions" for details

RES#: Reset input pin

For a correct device reset, provide an active low reset signal according to recommended operation conditions to input RES#.

CFG0 to CFG3: Configuration input pins

Set device configuration to preferred operation mode using CFG0 to CFG3. Leaving any configuration input unconnected may cause malfunction of the device. It is strongly recommended forcing all configuration input bits to either high or low level by using external pull up/down resistors. Do not use direct connection to VCC or VSS.

Note: CFGx are input pins during start up and output pins in normal operation mode. In order to prevent short circuit overload, a series resistor between CFGx and configuration device (example DIP switch) should be used. See also "typical application" for details.

CFG0/LED: Configuration input / LED output

CFG0/LED is scanned during reset to select the operation mode. Then CFG0/LED is switched to output and drives the diagnostic LED.

The LED shows the state of the bus line. Short blinking on time means no bus error or error warning state on the bus.

Long on time means that the CAN bus line is in error warning or bus off state.

CFG3/WD: Configuration input / watchdog output

CFG3/WD is scanned during reset to select the operation mode. Then CFG3/WD is switched to output and drives the watchdog trigger. To monitor correct device operation, this feature may be used in combination with an external watchdog timer.

Note: CFGx are input pins during start up and output pins in normal operation mode. In order to prevent short circuit overload a series resistor between CFGx and configuration device (example DIP switch) should be used. See also "typical application" for details.

CANRX, CANTX: CAN interface pins

The CAN interface pins may be used for direct connection to CAN transceivers like the 80C251. For longer bus length or noisy or disturbed environments it is strongly recommended to use galvanic isolation with optocouplers between bus interface and CANopen application, to improve system reliability.

Handling the Device**Preventing latch up**

The CO4013 is a CMOS device and may suffer latch up under the following conditions:

- 1) A voltage higher than VCC or lower than VSS is applied to any pin.
- 2) Absolute maximum ratings are exceeded
- 3) AVCC power is provided before VCC supply

Handling unused Pins

Do not leave unused input pins open. This might cause malfunction of the device.

Power Supply Pins

Make sure that all ground and power supply pins are connected to the same potential. Do not leave any ground or power pins open. Connect at least two ceramic capacitors of 100 nF and a tantalium capacitor of 1 uF between VCC and VSS as close as possible to the device.

Power Supply for A/D converter

The power supply for the A/D converter must not be turned on before the power supply VCC. It is recommended, to connect the pins as follows: AVCC = AVREF = VCC, AVSS = VSS.

Input / output pins

All input and output pins for digital signals are active low. This means for input pins, that inverted pin level is mapped to PDO. For output pins the inverted byte value from received PDO is written to the output pins. Additional inverting capabilities are supported.

Pull up/down resistors

The CO4013 does not support internal pull up/down resistors. Use external components where needed.

In Circuit programming of MB90F497

If you want to enable in circuit programming of the Fujitsu MB90F497 micro controller for CO4013 software download or update, the following conditions must be met.

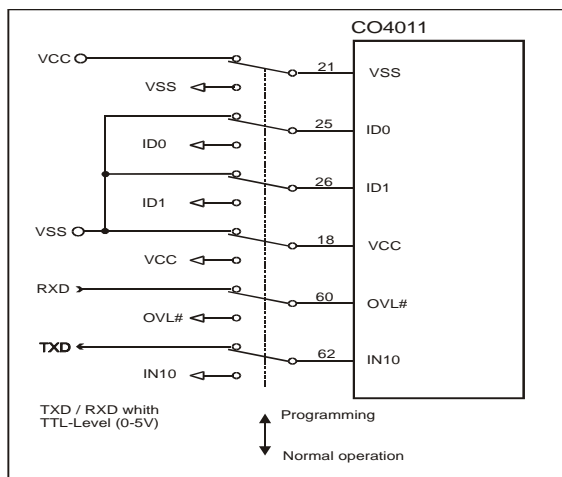

| Pin No. | Pin Name | Pin Setting for in circuit programming |
|---------|----------|--|
| 21 | VSS | Level = High |
| 18 | VCC | Level = Low |
| 25 | ID0 | Level = Low |
| 26 | ID1 | Level = Low |
| 60 | OVL# | RXD (TTL – logic level) |
| 62 | IN10 | TXD (TTL – logic level) |

Design example for programming adaptor.

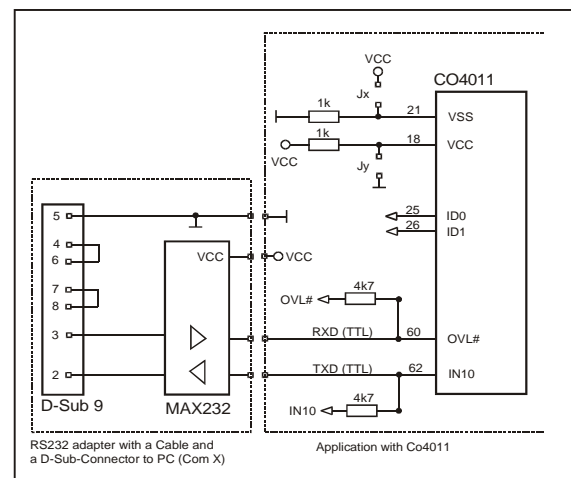

To enable the programming condition choose an identifier that forces the Pins ID0 and ID1 to low level. For example identifiers ID= 3, 7, 0x0B, 0x0F ... might be used. Close the jumpers Jx and Jy.

For optimised programming adaptor design, the programming adaptor should close the jumpers Jx and Jy directly by plugging the adaptor into the application board.

For normal operation mode the programming adaptor must be removed.

Note:
The in circuit programming is only necessary, if there is an option for updating the firmware of the CO4013 required.

Device Configuration

The following sections describe the device configuration with meaning:

- 1: ViH logic high level
- 0: ViL logic low level

CAN Identifier

The CAN Identifier will be set with Pins ID0 to ID6. This configuration pins use internal inverter. The ID is set as follows:

| ID6 | ID5 | ID4 | ID3 | ID2 | ID1 | ID0 | CAN-Identifier |
|-----|-----|-----|------|-----|-----|-----|----------------|
| 1 | 1 | 1 | 1 | 1 | 1 | 1 | Reserved |
| 1 | 1 | 1 | 1 | 1 | 1 | 0 | 1 = 0x01 |
| 1 | 1 | 1 | 1 | 1 | 0 | 1 | 2 = 0x02 |
| 1 | 1 | 1 | 1 | 1 | 0 | 0 | 3 = 0x03 |
| 1 | 1 | 1 | 1 | 0 | 1 | 1 | 4 = 0x04 |
| | | | | | | | |
| 1 | 0 | 0 | 0 | 0 | 0 | 0 | 63 = 0x3F |
| 0 | 1 | 1 | 1 | 1 | 1 | 1 | 64 = 0x40 |
| 0 | 1 | 1 | 1 | 1 | 1 | 0 | 65 = 0x41 |
| | | | | | | | |
| 0 | 0 | 0 | 0 | 0 | 1 | 0 | 125 = 0x7C |
| 0 | 0 | 0 | 0 | 0 | 0 | 1 | 126 = 0x7E |
| 0 | 0 | 0 | 0 | 0 | 0 | 0 | 127 = 0x7F |

Baud rate

The baud rate configuration will be done with configuration inputs BD0 to BD2

| BD2 | BD1 | BD0 | CAN-Baud Rate / Bus length |
|-----|-----|-----|----------------------------|
| 1 | 1 | 1 | 1 Mbit/sec 25 m *1) |
| 1 | 1 | 0 | 800 kbit/sec 50 m *1) |
| 1 | 0 | 1 | 500 kbit/sec 100 m *2) |
| 1 | 0 | 0 | 250 kbit/sec 250 m *2) |
| 0 | 1 | 1 | 125 kbit/sec 500 m *3) |
| 0 | 1 | 0 | 50 kbit/sec 1000 m *3) |
| 0 | 0 | 1 | 20 kbit/sec 2500 m *3) |
| 0 | 0 | 0 | 10 kbit/sec 5000 m *3) |

- *1) Calculation without optocouplers. For optocouplers bus length is reduced for about 4m per 10 nsec propagation delay of employed optocoupler type
- *2) Calculation with 40 nsec optocoupler propagation delay
- *3) Calculation with 100 nsec optocoupler propagation delay

The calculation of the bus length is based on a line propagation delay of 5 nsec/m.

Operation Mode: Nr of Supported axis

There are all four axis supported by default. In order to disable one or more axis connect the corresponding axis input lines (Pins 7..10) to pin 14 CFG0/LED.

Do not disable an axis, if you want to use another axis with higher number. Disabling of an axis will cause disable of all axis with higher numbers automatically. (X=1, Y=2, Z=3, W=4)

For example, if you disable axis 3 (pin Z-IN is connected to pin CFG0/LED), axis 4 (W-IN) will be disabled by default.

Operation Mode: Memory Function and I/O

The memory function is selected with pins CFG0, CFG1 and CFG2.

Note: This pins are input during reset, but switched to output during normal operation mode.

| CFG2 | CFG1 | CFG0 | Configuration Selected function |
|------|------|------|--|
| 1 | 1 | 1 | Mode-Type: CO4013A0 X-MEM .. W-MEM inputs (active low) for Push-Button Memory - Keys with internal analog input freezing feature. Push-Buttons are with Flip-Flop-Feature. Change of analog input voltage will not change Objects 6401 if Analog Input is frozen. OUT0 .. OUT3 are Diagnostic-LED output: 1 Analog Input released (not frozen) 0 Analog Input frozen (no change of Objects 6401) |
| 1 | 1 | 0 | Mode-Type: CO4013A1 X-MEM .. W-MEM inputs (active low) for Push-Button Memory - Keys without internal analog input freezing feature. Push-Buttons are with Flip-Flop-Feature. Change of analog input voltage will change Objects 6401 OUT0 .. OUT3 are Diagnostic-LED output: 1 Push-Button Flip-Flop is not set 0 Push-Button Flip-Flop is set Freezing of joystick position must be done by application |
| 1 | 0 | 1 | Mode-Type: CO4013A2 X-MEM .. W-MEM inputs for Switches (active low) as Memory - Keys with internal analog input freezing feature. Change of analog input voltage will not change Object 6401 if -MEM Input is low. OUT0 .. OUT3 are general purpose output pins |

| CFG | | | Configuration |
|-----|---|---|--|
| 2 | 1 | 0 | Selected function |
| 1 | 0 | 0 | Mode-Type: CO4013A3 X-MEM .. W-MEM inputs for Switches (active low) as Memory - Keys without internal analog input freezing feature. Change of analog input voltage will change Object 6401 in any case. OUT0 .. OUT3 are general purpose output pins. |
| 0 | 1 | 1 | Mode-Type: CO4013A4 X-MEM .. W-MEM pins are used as general-purpose input pins IN8 to IN11. There is no memory function supported. Change of analog input voltage will change Object 6401 in any case. OUT0 .. OUT3 are general purpose output pins. |
| 0 | 1 | 0 | Reserved for future use |
| 0 | 0 | 1 | Reserved for future use |
| 0 | 0 | 0 | Reserved for future use |

Customer specific configurations are available on request.

Operation Mode: CFG3

The function of Configuration Input line CFG3 is reserved for future use.

| CFG3 | Configuration |
|------|-------------------------|
| 1 | Normal operation mode |
| 0 | Reserved for future use |

Note: This pin is input during reset, but switched to output during normal operation mode.

Object Dictionary

The CO4013 Single Chip CANopen Controller implements a complex object dictionary for CANopen I/O devices.

For detailed information about CANopen objects see additional brochure "Introduction to CANopen"

For the Object tables all values are shown in hexadecimal way.

For access type the following settings are valid

ro read only

wo write only

rw read and write access enabled

DS301: global Objects

| Index | Sub-Index | Name | Acc. |
|-------|-----------|------------------------------------|------|
| 0005 | - | Dummy 8 | ro |
| 0006 | - | Dummy 16 | ro |
| 0007 | - | Dummy 32 | ro |
| 1000 | - | Device Type | ro |
| 1001 | - | Error Register | ro |
| 1002 | - | Manufacturer Status Register | ro |
| 1005 | - | COB-ID Sync Identifier Sync Object | rw |
| 1008 | - | Device Name | ro |
| 1009 | - | Hardware Version | ro |
| 100C | - | Guard Time | rw |
| 100D | - | Life Time Factor | rw |
| 100E | - | COB-ID Guard | rw |
| 1010 | - | Store Parameters *2) | rw |
| 1011 | - | Reload Default Parameter *2) | rw |
| 1014 | - | COB ID Emergency | rw |
| 1015 | - | Inhibit Time Emergency | rw |
| 1017 | - | Producer Heartbeat Time | rw |
| 1018 | 0 | Identity Object | ro |
| | 1 | Vendor ID | ro |
| | 2 | Product Code | ro |
| | 3 | Revision Number | ro |
| 2000 | - | Device Manufacturer *1) | ro |
| 2101 | - | System Configuration | ro |
| 2180 | - | CAN Restart Time | rw |

Notes:

- *1) This Objects shows "Frenzel + Berg" as visible string data type.
- *2) This object cannot be written to in operational device state.
Only use this command in preoperational device state, otherwise the CO4012 will answer requests with SDO abort telegrams.

The data type entries Index 0005 to 0007 are implemented for compatibility reasons. They may be mapped to PDOs in order to define the appropriate space in the PDO.

DS301: PDO Parameter Objects

Description of PDO Parameter objects:

These Objects enable dynamic PDO mapping, variable identifier distribution for PDOs and setting of the transmission mode, inhibit and event times. For the CO4013 setting of all parameters may be done in the device state "operational" as well as in "preoperational" state.

| Index | Sub-Index | Name | Acc. |
|---------------------|-----------|---|------|
| 1400 | 0 | Receive PDO1 Communication Parameter | ro |
| | 1 | COB-ID | rw |
| | 2 | Transmission Type | rw |
| | 3 | Inhibit Time (not used) | rw |
| | 4 | Reserved | rw |
| | 5 | Event Time | rw |
| 1401 ... 1403 | | Receive PDO2 to RPDO4 Communication Parameter same as 1400.00 .. 1400.05 | rw |
| 1600 | 0 | Receive PDO1: Parameter mapping | rw |
| | 1 to n | Mapped Object (max. 8 objects mappable) | rw |
| 1601 ... 1603 | | Receive PDO2 to RPDO4 Parameter mapping Same as 1600 | rw |
| 1800 | 0 | Transmit PDO1 Communication Parameter | ro |
| | 1 | COB-ID | rw |
| | 2 | Transmission Type | rw |
| | 3 | Inhibit Time | rw |
| | 4 | Reserved | rw |
| | 5 | Event Timer | rw |
| 1801 ... 1803 | | Transmit PDO2 to TPDO4 Communication Parameter same as 1800.00 .. 1800.05 | rw |
| 1A00 | 0 | Transmit PDO1 Parameter mapping | rw |
| | 1 to n | Mapped Object (max. 8 objects mappable) | rw |
| 1A01 ... 1A03 | | Transmit PDO2 to TPDO4 Parameter mapping Same as 1A00 | rw |

Note:

The CO4013A supports a maximum of 1 receive and 2 transmit PDOs. (according to configuration). All other Objects for higher PDO numbers are not implemented.

Note:

For detailed information about CANopen objects see additional brochure "Introduction to CANopen"

DS401: Digital Input Objects

| Index | Sub-Index | Name | Acc. |
|-------|-----------|---|------|
| 5003 | 0 to n | Debounce (Filter) time for each digital input | rw |
| 6000 | 0 to n | Read digital input 8 bit | ro |
| 6002 | 0 to n | Polarity input 8-bit | rw |
| 6005 | | Global interrupt enable | rw |
| 6006 | 0 to n | Interrupt mask: any change | rw |
| 6007 | 0 to n | Interrupt mask rising edge | rw |
| 6008 | 0 to n | Interrupt mask falling edge | rw |

The objects 5001 and 5002 are implemented for debug purposes, because the CANopen object 6000 does not allow write access to an input line. With objects 5001 and 5002 a debug environment may simulate setting or resetting of input lines. The CO4013 first scans the physical input lines and then processes the scanned values with the debug parameters.

With object 5003 an individual filter constant (value in msec) may be assigned to each input line. This gives great flexibility to prevent inputs from distortion. The default value for filter constant is 20 msec. The filter time is used for debouncing all input lines. Set value to 0 to disable debouncing of input lines.

DS401: Digital Output Objects

| Index | Sub-Index | Name | Acc. |
|-------|-----------|------------------------------|------|
| 6200 | 0 to n | Write Output 8 Bit | rw |
| 6202 | 0 to n | Change Polarity Output 8 bit | rw |
| 6206 | 0 to n | Error Mode Output | rw |
| 6207 | 0 to n | Error State Output | rw |

DS401: Analog Input Objects

| Index | Sub-Index | Name | Acc. |
|-------|-----------|---|------|
| 5401 | 0 to n | Zero Point Enlargement | rw |
| 6401 | 0 to n | Read Analog Input 16 Bit Axis proportional values | ro |
| 6421 | 0 to n | Analog Input Interrupt Trigger | rw |
| 6423 | | Analog Input global Interrupt Enable | rw |
| 6424 | 0 to n | Analog Input Upper Limit | rw |
| 6425 | 0 to n | Analog Input Lower Limit | rw |
| 6426 | 0 to n | Analog Input Interrupt Delta | rw |
| 6427 | 0 to n | Analog Input Interrupt Negative Delta | rw |
| 6428 | 0 to n | Analog input interrupt positive delta | rw |
| 6431 | 0 to n | Analog input offset integer | rw |

Description of Object Dictionary

The following list gives da short description of all dictionary entries.

Index 0005

This object is implemented to enable reservation of data space in PDOs by mapping dummy entries.

| | |
|---------------|------------|
| Index | 0005 |
| Name | Dummy 8 |
| Description | |
| Data Type | Unsigned 8 |
| Access modes | RO |
| PDO Mapping | Yes |
| Value Range | - |
| Default Value | 0 |

Index 0006

This object is implemented to enable reservation of data space in PDOs by mapping dummy entries.

| | |
|---------------|-------------|
| Index | 0006 |
| Name | Dummy 16 |
| Description | - |
| Data Type | Unsigned 16 |
| Access modes | RO |
| PDO Mapping | Yes |
| Value Range | - |
| Default Value | 0 |

Index 0007

This object is implemented to enable reservation of data space in PDOs by mapping dummy entries.

| | |
|---------------|-------------|
| Index | 0007 |
| Name | Dummy 32 |
| Description | - |
| Data Type | Unsigned 32 |
| Access modes | RO |
| PDO Mapping | Yes |
| Value Range | - |
| Default Value | 0 |

DS301: Global Objects

Index 1000 : Device Type

Description of the device type. The Object gives the CiA device profile number and additionally the functionality of the device.

| | | |
|---------------|----------------|----------------|
| Index | 1000h | |
| Name | Device Type | |
| Description | - | |
| Data Type | Unsigned 32 | |
| Access modes | RO | |
| PDO Mapping | No | |
| Value Range | - | |
| Default Value | Operation Mode | Value of Index |
| | CO4013A0 | 0105 0191 h |
| | CO4013A1 | 0105 0191 h |
| | CO4013A2 | 0107 0191 h |
| | CO4013A3 | 0107 0191 h |
| | CO4013A4 | 0107 0191 h |

Index 1001 : Error Register

This object holds an error of the device.

| | |
|---------------|----------------|
| Index | 1001h |
| Name | Error Register |
| Description | - |
| Data Type | Unsigned 8 |
| Access modes | RO |
| PDO Mapping | Yes |
| Value Range | - |
| Default Value | - |

The error register has the following structure

| Bit | Meaning |
|-----|--|
| 0 | Generic error. This bit is set, if any error is active |
| 1 | 0 |
| 2 | 0 |
| 3 | 0 |
| 4 | CAN bus or communication error |
| 5 | 0 |
| 6 | 0 |
| 7 | Device Error |

Index 1002 : Status Register

This object gives additional information for the device

| | |
|---------------|-----------------|
| Index | 1002h |
| Name | Status Register |
| Description | - |
| Data Type | Unsigned 32 |
| Access modes | RO |
| PDO Mapping | Yes |
| Value Range | - |
| Default Value | - |

The status register bits have the following meaning

| Bit | Meaning |
|-----|------------------------------------|
| 31 | The device is in operational state |
| 30 | Node guarding error |
| | |
| | |

Index 1005 : COB-ID Sync

Identifier of Can Object for the Synchronisation message. The CO4013 may only operate in Sync consumer mode. Generating of Sync messages is not possible. Nevertheless is the Identifier for the Sync message programmable.

| | |
|---------------|-------------|
| Index | 1005h |
| Name | COB-ID Sync |
| Description | - |
| Data Type | Unsigned 32 |
| Access modes | RW |
| PDO Mapping | No |
| Value Range | - |
| Default Value | - |

Index 1008 : Device Name

This object shows the name of the device as visible string.

| | |
|---------------|--|
| Index | 1008h |
| Name | Device Name |
| Description | - |
| Data Type | Visible String |
| Access modes | RO |
| PDO Mapping | No |
| Value Range | The maximum string length is 20 characters |
| Default Value | CO4013A |

Index 1009 : Hardware Version

This object shows the name of the device as visible string.

| | |
|---------------|--|
| Index | 1009h |
| Name | Hardware Version |
| Description | - |
| Data Type | Visible String |
| Access modes | RO |
| PDO Mapping | No |
| Value Range | The maximum string length is 20 characters |
| Default Value | - |

Index 100C : Guard Time

The objects at index 100Ch (Guard Time in milliseconds) and 100Dh (Life Time Factor) are used to implement the life guarding protocol. The Guard Time multiplied with the Life Time Factor gives the Life Time in milliseconds.

It is 0 (zero) if not used.

| | |
|---------------|-------------|
| Index | 100Ch |
| Name | Guard Time |
| Description | - |
| Data Type | Unsigned 16 |
| Access modes | RW |
| PDO Mapping | No |
| Value Range | |
| Default Value | 0 |

Index 100D : Life Time Factor

The objects at index 100Ch (Guard Time in milliseconds) and 100Dh (Life Time Factor) are used to implement the life guarding protocol. The Guard Time multiplied with the Life Time Factor gives the Life Time in milliseconds. It is 0 (zero) if not used.

| | |
|---------------|------------------|
| Index | 100Dh |
| Name | Life Time Factor |
| Description | - |
| Data Type | Unsigned 16 |
| Access modes | RW |
| PDO Mapping | No |
| Value Range | |
| Default Value | 0 |

Index 100E : COB-ID Guard

Identifier of Can Object for the Node Guarding or Heartbeat protocol.

| | |
|---------------|----------------|
| Index | 100Eh |
| Name | COB-ID Guard |
| Description | - |
| Data Type | Unsigned 32 |
| Access modes | RW |
| PDO Mapping | No |
| Value Range | - |
| Default Value | 700h + Node-ID |

Index 1010 : Store Parameters

This object supports the saving of parameters in 22non-volatile memory. By read access the device provides information about its saving capabilities. Several parameter groups are distinguished: Sub-Index 0 contains the largest Sub-Index that is supported.

Writing to Sub-Index 1 means that all parameters shall be stored on the device.

In order to avoid storage of parameters by mistake, storage is only executed when a specific signature is written to the appropriate Sub-Index. (This means that the signature is transferred as data bytes 4 to 7 in the CAN message of the corresponding SDO protocol.

The signature is "save".

| MSB | | LSB | |
|-----|-----|-----|-----|
| e | v | a | s |
| 65h | 76h | 61h | 73h |

On reception of the correct signature on sub-index 1 the device stores the parameters and then confirms the SDO transmission (initiate download response). If the storing failed, the device responds with an Abort SDO Transfer (abort code: 0606 0000 h). If a wrong signature is written, the device refuses to store and responds with Abort SDO Transfer (Abort code: 0800 002x h).

| | |
|-------------|------------------|
| Index | 1010h |
| Name | Store Parameters |
| Description | - |
| Data Type | Structure |

| | |
|---------------|----------------------------|
| Index | 1010h Subindex 0 |
| Name | Largest SubIndex supported |
| Description | - |
| Data Type | Unsigned char |
| Access modes | RO |
| PDO Mapping | No |
| Value Range | 1 |
| Default Value | 1 |

| | |
|---------------|--|
| Index | 1010h Subindex 1 |
| Name | Store All Parameters |
| Description | Writing to this object stores the dictionary to non-volatile memory. |
| Data Type | Unsigned 32 |
| Access modes | RW |
| PDO Mapping | No |
| Value Range | Signature "save" |
| Default Value | - |

By read access to object 1010h Subindex 1, the device responds with SDO data 00000001h indicating that storing of data is only done on command.

Note:

Writing to this object is only allowed in pre-operational mode.

Index 1011 : Restore Default Parameters

With this object the default values of parameters according to the communication or device profile are restored. By read access the device provides information about its capabilities to restore these values. Several parameter groups are distinguished: Sub-Index 0 contains the largest Sub-Index that is supported.

Writing to Sub-Index 1 restores all parameters that can be restored.

In order to avoid the restoring of default parameters by mistake, restoring is only executed when a specific signature is written to the appropriate sub-index. (This means that the signature is transferred as data bytes 4 to 7 in the CAN message of the corresponding SDO protocol.

The signature is "load".

| MSB | | LSB | |
|-----|-----|-----|-----|
| d | a | o | l |
| 64h | 61h | 6Fh | 6Ch |

On reception of the correct signature on sub-index 1 the device prepares restoring of the parameters at the next "reset node" command or on the next power on cycle and then confirms the SDO transmission (initiate download response). If failed, the device responds with an abort SDO transfer (abort code: 0606 0000h).

If a wrong signature is written, the device refuses to store and responds with Abort SDO Transfer (Abort code: 0800 002x h).

The default values are set valid after the device is reset (reset node) or power cycled. If the device requires storing on command (see Object 1010h), the appropriate command has to be executed after the reset if the default parameters are to be stored permanently.

| | |
|-------------|----------------------------|
| Index | 1011h |
| Name | Restore Default Parameters |
| Description | - |
| Data Type | Structure |

| | |
|---------------|----------------------------|
| Index | 1011h Subindex 0 |
| Name | Largest SubIndex supported |
| Description | - |
| Data Type | Unsigned char |
| Access modes | RO |
| PDO Mapping | No |
| Value Range | 1 |
| Default Value | 1 |

| | |
|---------------|--|
| Index | 1011h Subindex 1 |
| Name | Restore All Parameters |
| Description | Writing to this object prepares restoring of the default values to the dictionary at the next power cycle or "reset node" NMT. |
| Data Type | Unsigned 32 |
| Access modes | RW |
| PDO Mapping | No |
| Value Range | Signature "load" |
| Default Value | - |

By read access to object 1011h Subindex 1, the device responds with SDO data 00000001h indicating that restoring of default data is available.

Note:

Writing to this object is only allowed in pre-operational mode.

Index 1014 : COB-ID Emergency

Identifier of Can Object for the emergency messages.

| | |
|---------------|------------------|
| Index | 1014h |
| Name | COB-ID Emergency |
| Description | - |
| Data Type | Unsigned 32 |
| Access modes | RW |
| PDO Mapping | No |
| Value Range | - |
| Default Value | 80h + Node-ID |

Index 1015 : Inhibit Time Emergency

Inhibit Time for emergency messages. If the Inhibit Time is set to 0, inhibit delay is disabled. The Inhibit Time is a multiple of 100usec, but the CO4013A offers a maximum resolution of 1 millisecond.

| | |
|---------------|------------------------|
| Index | 1015h |
| Name | Inhibit Time Emergency |
| Description | - |
| Data Type | Unsigned 16 |
| Access modes | RW |
| PDO Mapping | No |
| Value Range | - |
| Default Value | 0 |

Index 1017 : Producer Heartbeat Time

The producer heartbeat time defines the cycle time of the heartbeat. The producer heartbeat time is 0 if it not used. The time has to be a multiple of 1ms.

| | |
|---------------|-------------------------|
| Index | 1017h |
| Name | Producer Heartbeat Time |
| Description | - |
| Data Type | Unsigned 16 |
| Access modes | RW |
| PDO Mapping | No |
| Value Range | - |
| Default Value | 0 |

Either Heartbeat or node guarding may be allowed at the same time. Do not use both protocols at the same time.

See additional brochure for further information.

Index 1018 : Identity Object

The object at index 1018h contains general information about the device and the manufacturer frenzel + berg elektronik. It cannot be modified.

| | |
|-------------|-----------------|
| Index | 1018h |
| Name | Identity Object |
| Description | - |
| Data Type | Structure |

| | |
|---------------|----------------------------|
| Index | 1018h Subindex 0 |
| Name | Largest SubIndex supported |
| Description | - |
| Data Type | Unsigned char |
| Access modes | RO |
| PDO Mapping | No |
| Value Range | - |
| Default Value | 3 |

| | |
|---------------|---|
| Index | 1018h Subindex 1 |
| Name | Vendor ID |
| Description | Registration Code of frenzel + berg elektronik at the CiA |
| Data Type | Unsigned 32 |
| Access modes | RO |
| PDO Mapping | No |
| Value Range | - |
| Default Value | 58h |

| | |
|---------------|--|
| Index | 1018h Subindex 2 |
| Name | Product Code |
| Description | Internal Product Code for CO4013A at frenzel + berg elektronik |
| Data Type | Unsigned 32 |
| Access modes | RO |
| PDO Mapping | No |
| Value Range | - |
| Default Value | 0104 0131 h |

| | |
|---------------|------------------------|
| Index | 1018h Subindex 3 |
| Name | Revision Code |
| Description | |
| Data Type | Unsigned 32 |
| Access modes | RO |
| PDO Mapping | No |
| Value Range | - |
| Default Value | Revision of the device |

Index 2000 : Device Manufacturer

This Object shows "Frenzel + Berg" as visible string.

| | |
|---------------|---------------------|
| Index | 2000h |
| Name | Device Manufacturer |
| Description | - |
| Data Type | Visible String |
| Access modes | RO |
| PDO Mapping | No |
| Value Range | - |
| Default Value | "Frenzel + Berg" |

Index 2101 : System Configuration

This Object returns the operation mode of the CO4013A. It represents the inverted Setting of the configuration input bits CFG0 to CFG3.

| | |
|---------------|-------------------------|
| Index | 2101h |
| Name | System Configuration |
| Description | - |
| Data Type | Unsigned 32 |
| Access modes | RO |
| PDO Mapping | No |
| Value Range | - |
| Default Value | Depends on CFG0 to CFG3 |

Index 2180 : CAN Restart Time

This Object provides the restart time out for the CAN communication layer in case of bus off errors in milliseconds.

If the restart time is set to 0 automatic restart of the device in case of bus off is prohibited.

| | |
|---------------|----------------------|
| Index | 2180h |
| Name | CAN Restart Time |
| Description | - |
| Data Type | Unsigned 16 |
| Access modes | RW |
| PDO Mapping | No |
| Value Range | - |
| Default Value | 0 (restart disabled) |

DS301: PDO Parameter Objects**Communication Parameter Objects**

The following table shows the communication parameter objects for Index 140x (Receive PDOs) and Index 180x (Transmit PDOs). The tables show Index 1400 as an example for all PDOs

The transmission type (sub-index 2) defines the mode for transmission / reception of the PDO. See table for detailed description of this entry.

Description of transmission type:

| Type | PDO transmission | | | | |
|---------|------------------|---------|--------------|--------|----------------|
| | cyclic | acyclic | Sync related | Async. | Only on remote |
| 0 | | X | X | | |
| 1-240 | X | | X | | |
| 241-251 | Reserved | | | | |
| 252 | | | X | | X |
| 253 | | | | X | X |
| 254 | | | | X | |
| 255 | | | | X | |

Synchronous (transmission types 0-240 and 252) means that the transmission of the PDO shall be related to the SYNC object. Asynchronous means that the transmission of the PDO is not related to the SYNC object.

A transmission type of zero means that the message shall be transmitted synchronously with the SYNC object but not periodically but only in case of data change.

A value between 1 and 240 means that the PDO is transferred synchronously and cyclically, the transmission type indicating the number of SYNC signals, which are necessary to trigger PDO transmissions or receptions.

The transmission types 252 and 253 mean that the PDO is only transmitted on reception of a remote frame. At transmission type 252, the data is updated (but not sent) immediately after reception of the SYNC object. At transmission type 253 the data is updated at the reception of the remote frame. These values are only possible for transmit PDOs.

Transmission type 254 selects the CanEASY mode. Transmission type 255 means, the application event is defined in the device profile. For receive PDOs the reception of a PDO will update the mapped data (normally the analog or digital outputs).

Sub-index 3h contains the inhibit time. This time is a minimum interval for PDO transmission. The value is defined as multiple of 100ms.

Sub-index 4h is reserved.

In mode 254/255 additionally an event time can be used for TPDO. If an event timer exists for a TPDO (value not equal to 0) the elapsed timer is considered to be an event. The event time is a multiple of 1 ms. This event will cause the transmission of this TPDO in addition to otherwise defined events.

| | |
|-------------|--|
| Index | 1400h |
| Name | Receive PDO1 Communication Parameters |
| Description | - |
| Data Type | Structure |

| | |
|---------------|----------------------------|
| Index | 1400h Subindex 0 |
| Name | Largest SubIndex supported |
| Description | - |
| Data Type | Unsigned 8 |
| Access modes | RO |
| PDO Mapping | No |
| Value Range | - |
| Default Value | 5 |

| | |
|---------------|------------------------------------|
| Index | 1400h Subindex 1 |
| Name | COB-ID |
| Description | Identifier for CAN-Object for PDO1 |
| Data Type | Unsigned 32 |
| Access modes | RW |
| PDO Mapping | No |
| Value Range | - |
| Default Value | 200h + Node-Id |

| | |
|---------------|-------------------|
| Index | 1400h Subindex 2 |
| Name | Transmission Type |
| Description | - |
| Data Type | Unsigned 8 |
| Access modes | RW |
| PDO Mapping | No |
| Value Range | - |
| Default Value | 0FFh |

| | |
|---------------|------------------|
| Index | 1400h Subindex 3 |
| Name | Inhibit Time |
| Description | - |
| Data Type | Unsigned 16 |
| Access modes | RW |
| PDO Mapping | No |
| Value Range | - |
| Default Value | 0 |

| | |
|---------------|------------------|
| Index | 1400h Subindex 4 |
| Name | Reserved |
| Description | - |
| Data Type | - |
| Access modes | - |
| PDO Mapping | No |
| Value Range | - |
| Default Value | - |

| | |
|---------------|------------------|
| Index | 1400h Subindex 5 |
| Name | Event Time |
| Description | - |
| Data Type | Unsigned 16 |
| Access modes | RW |
| PDO Mapping | No |
| Value Range | - |
| Default Value | 0 |

The PDO communication parameter objects have the same structure for all PDOs. The following Objects are used.

| | |
|-------|--|
| Index | PDO |
| 1400h | Receive PDO1 (digital output) |
| 1401h | Receive PDO2 (analog output) Not implemented in CO4013A |
| 1800h | Transmit PDO1 (digital input) |
| 1801h | Transmit PDO2 (analog input) |

PDO Mapping Objects

The following table shows the PDO Mapping Objects. The principle of PDO mapping is the same for all PDOs. The PDO Mapping table is the cross reference between the Object dictionary entries (for example the data of an digital output byte) and the data field inside an PDO data field (position in the data field of a CAN message for PDO transfer).

Subindex 0 determines the valid number of objects that have been mapped. The CO4013 allows a maximum of 8 mapped objects for each PDO. For changing the PDO mapping first subindex 0 must be set to 0 (mapping is deactivated). Then the objects can be remapped. When a new object is mapped by writing a subindex between 1 and 8, the device may check whether the object specified by index /subindex exists. If the object does not exist or the object cannot be mapped, the SDO transfer will be aborted.

If the special CAN features are enabled (CFG3=0), the CO4013 allows adding of additional mapping entries without resetting subindex 0. In this case the device calculates the number of mapped objects by itself and modifies subindex 0 respectively.

Subindexes 1 to 8 keep the pointers of the mapped objects as unsigned 32 values. The value is 0 if there is no mapped object. The structure for these pointers is as follows.

| | | | |
|--------------|-------|----------|--------|
| MSB | | LSB | |
| Byte3 | Byte2 | Byte1 | Byte0 |
| Mapped index | | Subindex | Length |

Mapped Index and Subindex together are the Pointer to the Object dictionary data to be mapped at this location.

Length gives the length of the mapped object in bits.

The PDO mapping objects have the same structure for all PDOs. The following Objects are used.

| Index | PDO |
|-------|---|
| 1600h | Receive PDO1 (digital output) Only valid if general purpose output pins are supported |
| 1601h | Receive PDO2 (analog output) Not implemented in CO4013A |
| 1A00h | Transmit PDO1 (digital input lines) |
| 1A01h | Transmit PDO2 (analog input) Representing the axis values of the joystick potentiometers |

The following mapping object uses index 1600 as an example for all mapping objects.

| | |
|-------------|---------------------------------|
| Index | 1600h |
| Name | Receive PDO1 Mapping Parameters |
| Description | - |
| Data Type | Array |

| | |
|---------------|-----------------------------|
| Index | 1600h Subindex 0 |
| Name | Largest SubIndex supported |
| Description | Number of mapped objects |
| Data Type | Unsigned 8 |
| Access modes | RW |
| PDO Mapping | No |
| Value Range | - |
| Default Value | According to operation mode |

| | |
|---------------|-----------------------------|
| Index | 1600h Subindex 1 to 8 |
| Name | Mapped object |
| Description | |
| Data Type | Unsigned 32 |
| Access modes | RW |
| PDO Mapping | No |
| Value Range | - |
| Default Value | According to operation mode |

Example:

As an example for PDO mapping, the following table shows the default mapping for transmit PDO1 in operation mode 0 (Push button memory keys).

| Index | Entry | Explanation |
|---------|-----------|--|
| 1A00.00 | 3 | There are 3 mapped objects in transmit PDO1 |
| 1A00.01 | 60000108h | First mapped object: Input Byte0 including state of push button flip-flop |
| 1A00.02 | 60000208h | First mapped object: Input Byte1 including state of direction control input lines X-POSITIVE..W-NEGATIVE |
| 1A00.03 | 60000308h | First mapped object: Input Byte2 including general-purpose input pins IN0 .. IN7 |

The data of the transmit PDO1 for this example will be three bytes.

All objects with PDO mapping capabilities (not only digital or analog I/O) may be mapped to one of the PDOs.

DS401: Digital Input Objects

The following objects are describing the functionality of the digital input lines of the CO4013A

Index 5003 : Debounce Time Digital Input

The CO4013A offers noise filtering for each digital input line. With object 5003 an individual filter time may be assigned to each input line. This allows direct connection of switches and push buttons without any external filter requirements.

The filter time is set in milliseconds. A value of 0 disables the filtering function.

| | |
|-------------|---------------------------|
| Index | 5003h |
| Name | Filter Time Digital Input |
| Description | - |
| Data Type | Array |

| | |
|---------------|-------------------------------|
| Index | Subindex 0 |
| Name | Nr of Subobjects |
| Description | |
| Data Type | Unsigned 8 |
| Access modes | RO |
| PDO Mapping | No |
| Value Range | - |
| Default Value | Number of digital input lines |

| | |
|---------------|---|
| Index | Subindex 1 to Nr of input lines |
| Name | Filter Time |
| Description | There is a individual Time for each input line. |
| Data Type | Unsigned 8 |
| Access modes | RW |
| PDO Mapping | No |
| Value Range | - |
| Default Value | 40 |

Index 6000 : Read Digital Input 8 Bit

This object represents the digital input bytes. The value of the input lines is written to this object.

If pushbutton support for memory function is supported, the corresponding input bit represents the state of the internal flip-flop.

The number of digital input bytes depends on the selected operation mode.

The mapping of the I/O lines to object 6000 is explained in chapter "Mapping I/O to Object Dictionary"

| | |
|-------------|---------------------|
| Index | 6000h |
| Name | Digital Input 8 Bit |
| Description | - |
| Data Type | Array |

| | |
|---------------|-----------------------------|
| Index | Subindex 0 |
| Name | Nr of Subobjects |
| Description | |
| Data Type | Unsigned 8 |
| Access modes | RO |
| PDO Mapping | No |
| Value Range | - |
| Default Value | Depending on operation mode |

| | |
|---------------|--|
| Index | Subindex 1 |
| Name | Digital Input 8 Bit Byte 0 |
| Description | Memory function for axis values One bit for each axis |
| Data Type | Unsigned 8 |
| Access modes | RO |
| PDO Mapping | Yes |
| Value Range | - |
| Default Value | Bitx = 0 : values are saved *1) Bitx = 1 : released |

*1) If there is a mode with internal analog input freezing feature, the analog input value (axis proportional value) is not changed, even if analog input voltage changes.

In operation modes without internal analog input freezing feature, the analog input value (axis proportional value) will change in the same way the input voltage changes. In this case the Bits only represent the state of the memory switches or push button flip-flops. The freezing of axis value must be done by the application in this case.

In configuration modes without any memory support (pins X-MEM to W-MEM are general purpose input pins IN8 to IN11) the default value for SubIndex1 is 0FFh.

| | |
|---------------|--|
| Index | Subindex 2 |
| Name | Digital Input 8 Bit Byte 1 |
| Description | State of Direction input bits (inverted level because active low) |
| Data Type | Unsigned 8 |
| Access modes | RO |
| PDO Mapping | Yes |
| Value Range | - |
| Default Value | Bit 0: X-POSITIVE Bit 1: X-NEGATIVE Bit 2: Y-POSITIVE Bit 3: Y-NEGATIVE Bit 4: Z-POSITIVE Bit 5: Z-NEGATIVE Bit 6: W-POSITIVE Bit 7: W-NEGATIVE |

There is no special function associated with the direction input bits, so they may be used for general-purpose input lines.

| | |
|---------------|--|
| Index | Subindex 3 |
| Name | Digital Input 8 Bit Byte 2 |
| Description | State of general purpose input bits Byte IN7.. IN0 (inverted level because active low) |
| Data Type | Unsigned 8 |
| Access modes | RO |
| PDO Mapping | Yes |
| Value Range | - |
| Default Value | |

| | |
|---------------|--|
| Index | Subindex 4 |
| Name | Digital Input 8 Bit Byte 3 |
| Description | State of general purpose input bits Byte IN11 .. IN8 (inverted level because active low) |
| Data Type | Unsigned 8 |
| Access modes | RO |
| PDO Mapping | Yes |
| Value Range | - |
| Default Value | |

If there is an operation mode with memory function selected, Subindex 4 is not implemented, because the corresponding pins are already mapped to Subindex 1.

Index 6002 : Polarity Input 8 Bit

With this object, the digital inputs may be inverted. See also Index 6000 for additional information. The number of digital input bytes depends on the selected operation mode.

| | |
|-------------|----------------------|
| Index | 6002h |
| Name | Polarity Input 8 Bit |
| Description | - |
| Data Type | Array |

| | |
|---------------|-------------------------------|
| Index | Subindex 0 |
| Name | Nr of Subobjects |
| Description | |
| Data Type | Unsigned 8 |
| Access modes | RO |
| PDO Mapping | No |
| Value Range | - |
| Default Value | Number of digital input bytes |

| | |
|---------------|---------------------------------|
| Index | Subindex 1 to Nr of input bytes |
| Name | Polarity Input 8 Bit Byte n |
| Description | |
| Data Type | Unsigned 8 |
| Access modes | RW |
| PDO Mapping | No |
| Value Range | - |
| Default Value | 0 |

Index 6005 : Global Interrupt Enable

This object enables or disables globally the interrupt behaviour without changing the interrupt masks. In event-driven mode the device transmits the input values depending on the interrupt masks in objects 6006h, 6007h, and 6008h and the PDO transmission type.

TRUE (1)= global interrupt enabled
FALSE (0)= global interrupt disabled

| | |
|---------------|-------------------------|
| Index | 6005h |
| Name | Global Interrupt Enable |
| Description | - |
| Data Type | Boolean |
| Access modes | RW |
| PDO Mapping | No |
| Value Range | - |
| Default Value | TRUE |

Index 6006 : Interrupt Mask Any Change

This object determines, which input lines shall activate an interrupt by any change of the input line. Both negative and positive edge will cause an interrupt, if enabled.

An interrupt will cause a PDO transmission in case of event driven transmission mode.

1 = interrupt enabled

0 = interrupt disabled

| | |
|-------------|---------------------------|
| Index | 6006h |
| Name | Interrupt Mask any change |
| Description | - |
| Data Type | Array |

| | |
|---------------|-------------------------------|
| Index | Subindex 0 |
| Name | Nr of Subobjects |
| Description | |
| Data Type | Unsigned 8 |
| Access modes | RO |
| PDO Mapping | No |
| Value Range | - |
| Default Value | Number of digital input bytes |

| | |
|---------------|---------------------------------|
| Index | Subindex 1 to Nr of input bytes |
| Name | Interrupt Mask any change |
| Description | |
| Data Type | Unsigned 8 |
| Access modes | RW |
| PDO Mapping | No |
| Value Range | - |
| Default Value | 0FFh (interrupt enabled) |

Index 6007/8 : Interrupt Mask on Edge

Object 6007 has the same structure and behaviour as object 6006h but will cause interrupts only on rising edge of object index 6000. Note that input lines are active low, so rising edge of input data (object 6000) means falling edge of input port line. Default value is 0.

Object 6008 has the same structure and behaviour as object 6006h but will cause interrupts only on falling edge of object index 6000. Note that input lines are active low, so falling edge of input data (object 6000) means rising edge of input port line. Default value is 0.

DS401: Digital Output Objects

The following objects are describing the functionality of the digital output lines of the CO4013A. The CO4013A supports only 8bit access. The objects are only implemented, if an operation mode with general purpose output pins is selected.

The number of digital output bytes depends on the selected operation mode.

Index 6200 : Write to Digital Output

With object 6200, the digital outputs of the CO4013A can be written to. Before writing to the output ports, the value of the bitmap of object 6200 is processed with object 6202 (Change polarity output 8 bit) and the inverted. (Output port bits of the CO4013A device are active low)

The mapping of the I/O lines to object 6200 is explained in chapter "Mapping I/O to Object Dictionary"

| | |
|-------------|-------------------------|
| Index | 6200h |
| Name | Write to digital output |
| Description | - |
| Data Type | Array |

| | |
|---------------|--------------------------|
| Index | Subindex 0 |
| Name | |
| Description | Number of mapped objects |
| Data Type | Unsigned 8 |
| Access modes | RO |
| PDO Mapping | NO |
| Value Range | - |
| Default Value | 1 |

| | |
|---------------|----------------------------------|
| Index | Subindex 1 to Nr of output bytes |
| Name | Write to digital output |
| Description | |
| Data Type | Unsigned 8 |
| Access modes | WO |
| PDO Mapping | YES |
| Value Range | - |
| Default Value | 0 |

Index 6202 : Polarity Output 8 Bit

With this object, the digital outputs may be inverted.
See also Index 6200 for additional information.

| | |
|-------------|-----------------------|
| Index | 6202h |
| Name | Polarity Output 8 Bit |
| Description | - |
| Data Type | Array |

| | |
|---------------|--------------------------------|
| Index | Subindex 0 |
| Name | Nr of Subobjects |
| Description | |
| Data Type | Unsigned 8 |
| Access modes | RO |
| PDO Mapping | No |
| Value Range | - |
| Default Value | Number of digital output bytes |

| | |
|---------------|---------------------------------|
| Index | Subindex 1 to Nr of input bytes |
| Name | Polarity Output 8 Bit Byte n |
| Description | |
| Data Type | Unsigned 8 |
| Access modes | RW |
| PDO Mapping | No |
| Value Range | - |
| Default Value | 0 |

Index 6206 : Error Mode Output 8 Bit

This object indicates, whether an output is forced to a predefined value (given in object 6207) in case of a device error.

1 = Output will be forced to the value selected in object 6207

0 = Output will be unchanged even in case of an error condition.

| | |
|-------------|-------------------------|
| Index | 6206h |
| Name | Error Mode Output 8 Bit |
| Description | - |
| Data Type | Array |

| | |
|---------------|--------------------------------|
| Index | Subindex 0 |
| Name | Nr of Subobjects |
| Description | |
| Data Type | Unsigned 8 |
| Access modes | RO |
| PDO Mapping | No |
| Value Range | - |
| Default Value | Number of digital output bytes |

| | |
|---------------|---|
| Index | Subindex 1 to Nr of input bytes |
| Name | Error Mode Output 8 Bit Byte n |
| Description | |
| Data Type | Unsigned 8 |
| Access modes | RW |
| PDO Mapping | No |
| Value Range | - |
| Default Value | 0FFh (Take error condition from object 6207) |

Index 6207 : Error Value Output 8 Bit

This object selects the level the outputs are forced to in case of device error mode if the error mode (object 6206 is enabled)

1 = Output will be forced to active state

0 = Output will be forced to inactive state.

Note: Outputs of CO4013 are active low.

| | |
|-------------|--------------------------|
| Index | 6207h |
| Name | Error Value Output 8 Bit |
| Description | - |
| Data Type | Array |

| | |
|---------------|--------------------------------|
| Index | Subindex 0 |
| Name | Nr of Subobjects |
| Description | |
| Data Type | Unsigned 8 |
| Access modes | RO |
| PDO Mapping | No |
| Value Range | - |
| Default Value | Number of digital output bytes |

| | |
|---------------|---------------------------------|
| Index | Subindex 1 to Nr of input bytes |
| Name | Error Value Output 8 Bit Byte n |
| Description | |
| Data Type | Unsigned 8 |
| Access modes | RW |
| PDO Mapping | No |
| Value Range | - |
| Default Value | 0 (Inactive, high level) |

DS401: Analog Input Objects

The following objects are describing the functionality of the analog input lines of the CO4013A.

The number of analog input bytes depends on the number of supported axis.

Index 5401 : Axis Zero Point Enlargement

With Object 5401, the zero area of the joystick may be enlarged. The Axis Value will be forced to zero, if the analog input voltage from the axis potentiometer is less than Object 5401. In this case the Joystick may be moved in the zero position without setting an input voltage.

The axis position value (object 6401) will be calculated as follows:

If $6401 > 5401$ then $6401 = 6401 - 5401$

Else if $6401 < -5401$ then $6401 = 6401 + 5401$

Else $6401 = 0$

| | |
|-------------|--------------------------------|
| Index | 5401h |
| Name | Axis zero position enlargement |
| Description | - |
| Data Type | Array |

| | |
|---------------|--------------------------|
| Index | Subindex 0 |
| Name | |
| Description | Number of mapped objects |
| Data Type | Unsigned 8 |
| Access modes | RO |
| PDO Mapping | NO |
| Value Range | - |
| Default Value | Number of axis |

| | |
|---------------|---------------------------------|
| Index | Subindex 1 to Nr of input lines |
| Name | Axis zero position enlargement |
| Description | See above |
| Data Type | unsigned 16 |
| Access modes | RW |
| PDO Mapping | NO |
| Value Range | - |
| Default Value | 1000h |

Index 6401 : Joystick Position 16 Bit

Object 6401, represent the values of the axis potentiometers. The position of the joystick potentiometer is coded as a 16 bit conversion result of the analog input voltage in a signed value. Therefore voltages less than 2.5V are read as negative input voltage. An input of 2.5V is read as 0 (zero position of joystick axis) and an input voltage higher than 2.5V is converted into positive values. If the application requires reading of the analog input voltage as unsigned values, the object 6431 may be used for adding an offset to the conversion result.

The mapping of the I/O lines to object 6401 is explained in chapter "Mapping I/O to Object Dictionary"

| | |
|-------------|-------------------|
| Index | 6401h |
| Name | Read Analog Input |
| Description | - |
| Data Type | Array |

| | |
|---------------|--------------------------|
| Index | Subindex 0 |
| Name | |
| Description | Number of mapped objects |
| Data Type | Unsigned 8 |
| Access modes | RO |
| PDO Mapping | NO |
| Value Range | - |
| Default Value | Number of axis |

| | |
|---------------|---------------------------------|
| Index | Subindex 1 to Nr of input lines |
| Name | Read Analog Input |
| Description | Proportional axis input |
| Data Type | Signed 16 |
| Access modes | RO |
| PDO Mapping | YES |
| Value Range | - |
| Default Value | - |

Index 6421 : Analog Input Interrupt Trigger

Object 6421 selects the event that shall cause a transmission interrupt for the selected analog channel.

There is one Subindex for each channel to enable individual setting according to application requirements.

Table of possible Trigger Conditions:

| | |
|--------|--|
| Bit Nr | Interrupt Trigger Selection |
| 0 | Input voltage greater than Upper Limit |
| 1 | Input voltage less than Lower Limit |
| 2 | Input changed by more than Delta |
| 3 | Input reduced more than Negative Delta |
| 4 | Input increased more than Positive Delta |
| 5 to 7 | Reserved (must be forced to zero) |

| | |
|-------------|--------------------------------|
| Index | 6421h |
| Name | Analog Input Interrupt Trigger |
| Description | - |
| Data Type | Array |

| | |
|---------------|------------------------------|
| Index | Subindex 0 |
| Name | |
| Description | Number of mapped objects |
| Data Type | Unsigned 8 |
| Access modes | RO |
| PDO Mapping | NO |
| Value Range | - |
| Default Value | Number of analog input lines |

| | |
|---------------|--|
| Index | Subindex 1 to Nr of input lines |
| Name | Analog Input Interrupt Trigger |
| Description | Selects trigger condition |
| Data Type | Unsigned 8 (See Table of Trigger Conditions) |
| Access modes | RW |
| PDO Mapping | No |
| Value Range | - |
| Default Value | 7 |

Index 6423 : Analog Input Interrupt Enable

This object enables or disables globally the interrupt behaviour without changing the interrupt masks. The interrupt is disabled by default, in order to avoid transmission of analog input values.

TRUE (1)= global interrupt enabled
FALSE (0)= global interrupt disabled

| | |
|---------------|-------------------------------|
| Index | 6423h |
| Name | Analog Input Interrupt Enable |
| Description | - |
| Data Type | Boolean |
| Access modes | RW |
| PDO Mapping | No |
| Value Range | - |
| Default Value | FALSE |

**Index 6424/5/6/7/8 :
Analog Input Interrupt Limits**

These objects give the Limit for generation of interrupts. All objects have the same structure. The function of the interrupt limit is only enabled, if the corresponding bit of object 6421 is set. All values of limit parameters are signed 32. So the user must take care not to exceed the range of the input data objects.

Table of Limit Function

| Object | Object Name and Function |
|--------|--|
| 6424 | Analog Input Upper Limit Generate interrupt if input voltage is greater than Upper Limit (6424) |
| 6425 | Analog Input Lower Limit Generate interrupt if input voltage is less than Lower Limit (6425) |
| 6426 | Analog Input Interrupt Delta Generate interrupt if input voltage changed by more than Interrupt Delta |
| 6427 | Analog Input Negative Delta Generate interrupt if input voltage reduced by more than Negative Delta |
| 6428 | Analog Input Positive Delta Generate interrupt if input voltage increased by more than Positive Delta |

| | |
|-------------|-----------------|
| Index | 6424/5/6/7/8/9 |
| Name | See table above |
| Description | - |
| Data Type | Array |

| | |
|---------------|------------------------------|
| Index | Subindex 0 |
| Name | |
| Description | Number of mapped objects |
| Data Type | Unsigned 8 |
| Access modes | RO |
| PDO Mapping | NO |
| Value Range | - |
| Default Value | Number of analog input lines |

| | |
|---------------|---------------------------------|
| Index | Subindex 1 to Nr of input lines |
| Name | See table above |
| Description | |
| Data Type | Integer 32 |
| Access modes | RW |
| PDO Mapping | No |
| Value Range | - |
| Default Value | 0 |

Index 6431 : Analog Input Offset

Object 6431 adds an offset value to the analog input data object (6400 / 6401).

The normal input scaling for analog data objects 6400 and 6401 considers conversion of negative input voltages (input amplifier must shift to positive voltages because input port pin is 0 to 5V only) by placing the zero point (of data) to 2.5V. (middle of input voltage range)

If application requires only positive input values an offset may be add with object 6431, in order to adjust the zero point for data to an input voltage of 0V. For 8 Bit analog conversion (object 6400) the offset value (object 6431) must be 80h. For 16 Bit analog conversion (object 6401) the offset value must be set to 8000h.

| | |
|-------------|---------------------|
| Index | 6431h |
| Name | Analog Input Offset |
| Description | - |
| Data Type | Array |

| | |
|---------------|------------------------------|
| Index | Subindex 0 |
| Name | |
| Description | Number of mapped objects |
| Data Type | Unsigned 8 |
| Access modes | RO |
| PDO Mapping | NO |
| Value Range | - |
| Default Value | Number of analog input lines |

| | |
|---------------|---------------------------------|
| Index | Subindex 1 to Nr of input lines |
| Name | Analog Input Offset |
| Description | |
| Data Type | Signed 32 |
| Access modes | RW |
| PDO Mapping | No |
| Value Range | - |
| Default Value | 0 |

Emergency Messages

The CO4013 supports several emergency messages. For all emergencies the same structure is used:

| Byte | | | | | | | | |
|----------|------|---|-------------|---|---|---|---|--|
| 0 | 1 | 2 | 3 | 4 | 5 | 6 | 7 | |
| EMY-Code | 1001 | 0 | CO4011-Code | | | | | |

EMY-Code: Emergency-Error-Code according to DS301

1001: Content of Object 1001

CO4011-Code: Emergency-Error-Code for CO4011 as unsigned 32 value

| CO4013-Code (hex) | May change | | Description |
|-------------------|------------|-----|--------------------------------|
| | NMT | I/O | |
| 8000 0000 | X | X | CAN bus is bus off |
| 4000 0000 | | | CAN bus in error warning state |
| 3000 0000 | X | X | Life guarding error |

If more than one error is active at the same time, the bitmap of the CO4013-Codes for all active errors are combined with a logical or conjunction.

Some of the emergencies may cause a NMT state change and/or may force the output pins to the error state.

The ID for emergency transmission is fixed to: 0x80 + \$NodeID.

List of emergency messages:

| Life-Guarding Error | | | | | | | |
|---------------------|----|----|----|----|----|----|----|
| 30 | 81 | 11 | 00 | 00 | 00 | 00 | 00 |

This error occurs, if the masters fails to transmit the guarding remote frame within the specified Life Time (Guard Time object 100C multiplied with Life Time Factor object 100D)

| CAN Bus in Error Warning state | | | | | | | |
|--------------------------------|----|----|----|----|----|----|----|
| 00 | 81 | 11 | 00 | 00 | 00 | 00 | 00 |

This error occurs, if the chips internal CAN module is in error warning state.

| Return from CAN Bus OFF | | | | | | | |
|-------------------------|----|----|----|----|----|----|----|
| 40 | 81 | 11 | 00 | 00 | 00 | 00 | 00 |

This message indicates a return from Bus OFF state.

| cable break detection | | | | | | | |
|-----------------------|----|----|----|----|----|----|----|
| 20 | 31 | 81 | 00 | 8x | 00 | 00 | 00 |

| Error bits | | |
|------------|------|--------|
| | bit0 | x-axis |
| | bit1 | y-axis |
| | bit2 | z-axis |
| | bit3 | w-axis |

This error occurs, if the axis is active and a cable isn't connected or broken.

Mapping I/O to Object Dictionary

The mapping of the I/O channels depends on the setting of configuration bits CFG0 to CFG3. All possible configurations are shown in individual tables. Select the table for your application according to your joystick I/O requirements.

Note for A/D converter the resolution is fixed with 10 bit. Tables that show analog input with 16-bit mean, that dictionary entry is made as signed integer (16 bit wide).

The following tables are describing the Mapping of the I/O to the dictionary considering there is a 4 axis joystick connected. If there are less then 4 axis, the objects for deactivated axis are not implemented.

See chapter "Device Configuration" for more information how to disable any axis.

Customer specific configurations are available on request.

*1) These modes are reserved for future use and must not be set. Selecting the reserved modes may cause improper operation of the device.

See chapters "Device Configuration" and "Operation Mode: Memory Function and I/O" for further information about the operation modes.

The selected operation mode may be read via object 2101h from the object dictionary.

Note:

Setting of configuration must be fixed. The CO4013 scans the setting of CFG0 to CFG3 only during reset. Changing of configuration on the fly is not allowed and may cause improper operation of the device.

Note:

CFGx are input pins during start up and output pins in normal operation mode. In order to prevent short circuit overload, a series resistor between CFGx and configuration device (example DIP switch) should be used. See also "typical application" for details.

Summary of operation modes

The following table shows a summary of possible operation modes.

| CFG | | | | Mode | Description |
|-----|---|---|---|------|--|
| 3 | 2 | 1 | 0 | | |
| 1 | 1 | 1 | 1 | 0 | Memory function with push button internal analog value freeze |
| 1 | 1 | 1 | 0 | 1 | Memory function with push button no internal analog value freeze |
| 1 | 1 | 0 | 1 | 2 | Memory function with switches internal analog value freeze |
| 1 | 1 | 0 | 0 | 3 | Memory function with switches no internal analog value freeze |
| 1 | 0 | 1 | 1 | 4 | No memory function |
| 1 | 0 | 1 | 0 | 5 | reserved *1) |
| 1 | 0 | 0 | 1 | 6 | reserved *1) |
| 1 | 0 | 0 | 0 | 7 | reserved *1) |
| 0 | x | x | X | | reserved *1) |

I/O-Mapping in Mode 0

Memory Push Button with internal freeze

| Operation mode 0 CFG 3 = 1 CFG 2 = 1 CFG1 = 1 CFG0 = 1 EDS-file: CO4013A0.EDS Memory function available (internal) with push button with internal analog value freeze (analog axis value Object 6401 will not change if memory flip-flop is set) 16 direction- and general purpose digital input lines 4 diagnostic LED output lines for freezing feature | | | | | | | | |
|---|--|---------|---------|---------|---------------------|---------|---------|---------|
| Data Mapping to Dictionary | | | | | | | | |
| Index. SubIndex | Mapped I/O Signal bit/value | | | | | | | |
| | 7 | 6 | 5 | 4 | 3 | 2 | 1 | 0 |
| 6000.01 MEMORY- Input Or -Flip-Flop | 0 | 0 | 0 | 0 | W | Z | Y | X |
| | | | | | -MEM (Flip-Flop) | | | |
| 6000.02 Direction-Input | W- N | W- P | Z- N | Z- P | Y- N | Y- P | X- N | X- P |
| | P POSITIVE input N NEGATIVE input (inverted input polarity) | | | | | | | |
| 6000.03 General- Purpose Input | IN7 .. IN0 | | | | | | | |
| 6401.01 | X-Axis proportional value (16 bit) | | | | | | | |
| 6401.02 | Y-Axis proportional value (16 bit) | | | | | | | |
| 6401.03 | Z-Axis proportional value (16 bit) | | | | | | | |
| 6401.04 | W-Axis proportional value (16 bit) | | | | | | | |
| Default PDO Mapping | | | | | | | | |
| PDO | Mapped Data | | | | | | | |
| RPDO1 | Not implemented | | | | | | | |
| TPDO1 | 6000.01 Memory Input 6000.02 Direction Input 6000.03 General-Purpose Input | | | | | | | |
| TPDO2 | 6401.01 X-Axis proportional value 6401.02 Y-Axis proportional value 6401.03 Z-Axis proportional value 6401.04 W-Axis proportional value | | | | | | | |

I/O-Mapping in Mode 1

Memory Push Button no internal freeze

| Operation mode 1 CFG 3 = 1 CFG 2 = 1 CFG1 = 1 CFG0 = 0 EDS-file: CO4013A1.EDS Memory function available (by application) with push button no internal analog value freeze (change of analog axis value will change Object 0x6401) 16 direction- and general purpose digital input lines 4 diagnostic LED output lines for freezing feature | | | | | | | | |
|--|--|---------|---------|---------|---------------------|---------|---------|---------|
| Data Mapping to Dictionary | | | | | | | | |
| Index. SubIndex | Mapped I/O Signal bit/value | | | | | | | |
| | 7 | 6 | 5 | 4 | 3 | 2 | 1 | 0 |
| 6000.01 MEMORY- Input Or -Flip-Flop | 0 | 0 | 0 | 0 | W | Z | Y | X |
| | | | | | -MEM (Flip-Flop) | | | |
| 6000.02 Direction-Input | W- N | W- P | Z- N | Z- P | Y- N | Y- P | X- N | X- P |
| | P POSITIVE input N NEGATIVE input (inverted input polarity) | | | | | | | |
| 6000.03 General- Purpose Input | IN7 .. IN0 | | | | | | | |
| 6401.01 | X-Axis proportional value (16 bit) | | | | | | | |
| 6401.02 | Y-Axis proportional value (16 bit) | | | | | | | |
| 6401.03 | Z-Axis proportional value (16 bit) | | | | | | | |
| 6401.04 | W-Axis proportional value (16 bit) | | | | | | | |
| Default PDO Mapping | | | | | | | | |
| PDO | Mapped Data | | | | | | | |
| RPDO1 | Not implemented | | | | | | | |
| TPDO1 | 6000.01 Memory Input 6000.02 Direction Input 6000.03 General-Purpose Input | | | | | | | |
| TPDO2 | 6401.01 X-Axis proportional value 6401.02 Y-Axis proportional value 6401.03 Z-Axis proportional value 6401.04 W-Axis proportional value | | | | | | | |

I/O-Mapping in Mode 2

Memory Switch with internal freeze

| <p>Operation mode 2 CFG 3 = 1 CFG 2 = 1 CFG1 = 0 CFG0 = 1 EDS-file: CO4013A2.EDS Memory function available (internal) with switch with internal analog value freeze (analog axis value Object 6401 will not change if memory flip-flop is set) 16 direction- and general purpose digital input lines 4 general purpose output lines</p> | | | | | | | | |
|--|--|---------|---------|---------|---------------------|---------|---------|---------|
| Data Mapping to Dictionary | | | | | | | | |
| Index. SubIndex | Mapped I/O Signal bit/value | | | | | | | |
| | 7 | 6 | 5 | 4 | 3 | 2 | 1 | 0 |
| 6000.01 MEMORY- Input Or -Flip-Flop | 0 | 0 | 0 | 0 | W | Z | Y | X |
| | | | | | -MEM (Flip-Flop) | | | |
| 6000.02 Direction-Input | W- N | W- P | Z- N | Z- P | Y- N | Y- P | X- N | X- P |
| | P POSITIVE input N NEGATIVE input (inverted input polarity) | | | | | | | |
| 6000.03 General- Purpose Input | IN7 .. IN0 | | | | | | | |
| 6200.01 General- Purpose Output | - | - | - | - | OUT3 .. OUT0 | | | |
| 6401.01 | X-Axis proportional value (16 bit) | | | | | | | |
| 6401.02 | Y-Axis proportional value (16 bit) | | | | | | | |
| 6401.03 | Z-Axis proportional value (16 bit) | | | | | | | |
| 6401.04 | W-Axis proportional value (16 bit) | | | | | | | |
| Default PDO Mapping | | | | | | | | |
| PDO | Mapped Data | | | | | | | |
| RPDO1 | 6200.01 General-Purpose Output | | | | | | | |
| TPDO1 | 6000.01 Memory Input 6000.02 Direction Input 6000.03 General-Purpose Input | | | | | | | |
| TPDO2 | 6401.01 X-Axis proportional value 6401.02 Y-Axis proportional value 6401.03 Z-Axis proportional value 6401.04 W-Axis proportional value | | | | | | | |

I/O-Mapping in Mode 3

Memory Switch no internal freeze

| <p>Operation mode 3 CFG 3 = 1 CFG 2 = 1 CFG1 = 0 CFG0 = 0 EDS-file: CO4013A3.EDS Memory function available (by application) with switch no internal analog value freeze (change of analog axis value will change Object 0x6401) 16 direction- and general purpose digital input lines 4 general purpose output lines</p> | | | | | | | | |
|---|--|---------|---------|---------|---------------------|---------|---------|---------|
| Data Mapping to Dictionary | | | | | | | | |
| Index. SubIndex | Mapped I/O Signal bit/value | | | | | | | |
| | 7 | 6 | 5 | 4 | 3 | 2 | 1 | 0 |
| 6000.01 MEMORY- Input Or -Flip-Flop | 0 | 0 | 0 | 0 | W | Z | Y | X |
| | | | | | -MEM (Flip-Flop) | | | |
| 6000.02 Direction-Input | W- N | W- P | Z- N | Z- P | Y- N | Y- P | X- N | X- P |
| | P POSITIVE input N NEGATIVE input (inverted input polarity) | | | | | | | |
| 6000.03 General- Purpose Input | IN7 .. IN0 | | | | | | | |
| 6200.01 General- Purpose Output | - | - | - | - | OUT3 .. OUT0 | | | |
| 6401.01 | X-Axis proportional value (16 bit) | | | | | | | |
| 6401.02 | Y-Axis proportional value (16 bit) | | | | | | | |
| 6401.03 | Z-Axis proportional value (16 bit) | | | | | | | |
| 6401.04 | W-Axis proportional value (16 bit) | | | | | | | |
| Default PDO Mapping | | | | | | | | |
| PDO | Mapped Data | | | | | | | |
| RPDO1 | 6200.01 General-Purpose Output | | | | | | | |
| TPDO1 | 6000.01 Memory Input 6000.02 Direction Input 6000.03 General-Purpose Input | | | | | | | |
| TPDO2 | 6401.01 X-Axis proportional value 6401.02 Y-Axis proportional value 6401.03 Z-Axis proportional value 6401.04 W-Axis proportional value | | | | | | | |

I/O-Mapping in Mode 4

No Memory function

| Operation mode 4 CFG 3 = 1 CFG 2 = 0 CFG1 = 1 CFG0 = 1 EDS-file: CO4013A4.EDS No Memory function 20 direction- and general purpose digital input lines 4 general purpose output lines | | | | | | | | |
|--|--|---------|---------|---------|---------------------|---------|---------|---------|
| Data Mapping to Dictionary | | | | | | | | |
| Index. SubIndex | Mapped I/O Signal bit/value | | | | | | | |
| | 7 | 6 | 5 | 4 | 3 | 2 | 1 | 0 |
| 6000.01 MEMORY- Input Or -Flip-Flop | 0 | 0 | 0 | 0 | 0 | 0 | 0 | 0 |
| All Memory flags forced to 0 | | | | | | | | |
| 6000.02 Direction-Input | W- N | W- P | Z- N | Z- P | Y- N | Y- P | X- N | X- P |
| P POSITIVE input N NEGATIVE input *1) | | | | | | | | |
| 6000.03 General- Purpose Input | IN7 .. IN0 *1) | | | | | | | |
| 6000.04 General- Purpose Input | 0 | 0 | 0 | 0 | IN11 .. IN8 *1) | | | |
| 6200.01 General- Purpose Output | - | - | - | - | OUT3 .. OUT0 *1) | | | |
| 6401.01 | X-Axis proportional value (16 bit) | | | | | | | |
| 6401.02 | Y-Axis proportional value (16 bit) | | | | | | | |
| 6401.03 | Z-Axis proportional value (16 bit) | | | | | | | |
| 6401.04 | W-Axis proportional value (16 bit) | | | | | | | |
| Default PDO Mapping | | | | | | | | |
| PDO | Mapped Data | | | | | | | |
| RPDO1 | 6200.01 General-Purpose Output | | | | | | | |
| TPDO1 | 6000.01 Memory Input (forced to 0) 6000.02 Direction Input 6000.03 General-Purpose Input 6000.04 General-Purpose Input | | | | | | | |
| TPDO2 | 6401.01 X-Axis proportional value 6401.02 Y-Axis proportional value 6401.03 Z-Axis proportional value 6401.04 W-Axis proportional value | | | | | | | |

*1) Note: The CO4013 has inverted input/output pin polarity.

Absolute Maximum Ratings

Stresses greater than those listed parameters may cause permanent damage to the device. Functional operation should be restricted to recommended operation conditions. Exposure to absolute maximum rating conditions for extended times may affect reliability.

| Parameter | Symbol | Rated Value | | Units | Remarks |
|--------------------------------|------------------|-------------|-----------|-------|-----------------|
| | | Min. | Max. | | |
| Power supply voltage | VCC | VSS – 0.3 | VSS + 6.0 | V | |
| Analog power supply voltage | AVCC | VSS – 0.3 | VCC | V | |
| Analog reference voltage | AVREF | VSS – 0.3 | VCC | V | |
| Input voltage | Vi | VSS – 0.3 | VSS + 6.0 | V | Vi < VCC + 0.3V |
| Output voltage | Vo | VSS – 0.3 | VSS + 6.0 | V | Vo < VCC + 0.3V |
| L level maximum output current | IOLMAX | | 15 | mA | Time < 20 msec |
| L level maximum output current | IOL | | 4 | mA | |
| H level maximum output current | IOHMAX | | 15 | mA | Time < 20 msec |
| H level maximum output current | IOH | | 4 | mA | |
| Maximum Power dissipation | P _{MAX} | | 300 | mW | |
| Operating temperature | T _A | -40 | +85 | °C | CO4013A |
| | T _A | -40 | +105 | °C | CO4013AE |
| Storing temperature | T _A | -55 | +150 | °C | |

Operation Conditions / Characteristics

Functional operation should be restricted to recommended operation conditions.

| Parameter | Symbol | Rated Value | | | Units | Remarks |
|--|--------------------|-------------|------|-----------|-------|---|
| | | Min. | Typ. | Max. | | |
| Power supply voltage | VCC | 4.5 | 5.0 | 5.5 | V | |
| Analog power supply voltage | AVCC | | VCC | VCC | V | |
| Analog reference voltage | AVREF | | VCC | VCC | V | |
| Power supply current | I _{CC} | | 35 | 50 | mA | All inputs V _{IL} or V _{IH} All outputs open |
| Input H voltage | V _{IH} | 0.8 * VCC | | VCC + 0.3 | V | |
| Input L voltage | V _{IL} | VSS – 0.3 | | 0.2 * VCC | V | |
| Output H voltage | V _{OH} | VCC – 0.5 | | | V | I _{OH} = -4.0 mA |
| Output L voltage | V _{OL} | | | 0.4 | V | I _{OL} = 4.0 mA |
| Input leakage current | I _{LKC} | -5 | | 5 | µA | |
| Crystal frequency | f _{osc} | | 4 | | MHz | |
| Reset pulse width | t _{res} | 10 | | | µs | |
| Power on rise time | t _{RESLH} | 0.05 | | 30 | ms | |
| Maximum CANopen Delay input pin to bus telegram | t _{DITB} | 0.05 | 1 | 2 | ms | No additional bus distribution delay |
| Maximum CANopen Delay bus telegram to output pin | t _{DBTO} | 0.05 | 1 | 2 | ms | |
| Watchdog trigger frequency | f _{WDT} | 0.5 | 1 | 2 | kHz | Delayed max. 500 ms after reset |
| Maximum Power dissipation | P _{MAX} | | | 300 | mW | |
| Operating temperature | T _A | -40 | | +85 | °C | CO4013A |
| | T _A | -40 | | +105 | °C | CO4013AE |

Package Dimension CO4013A

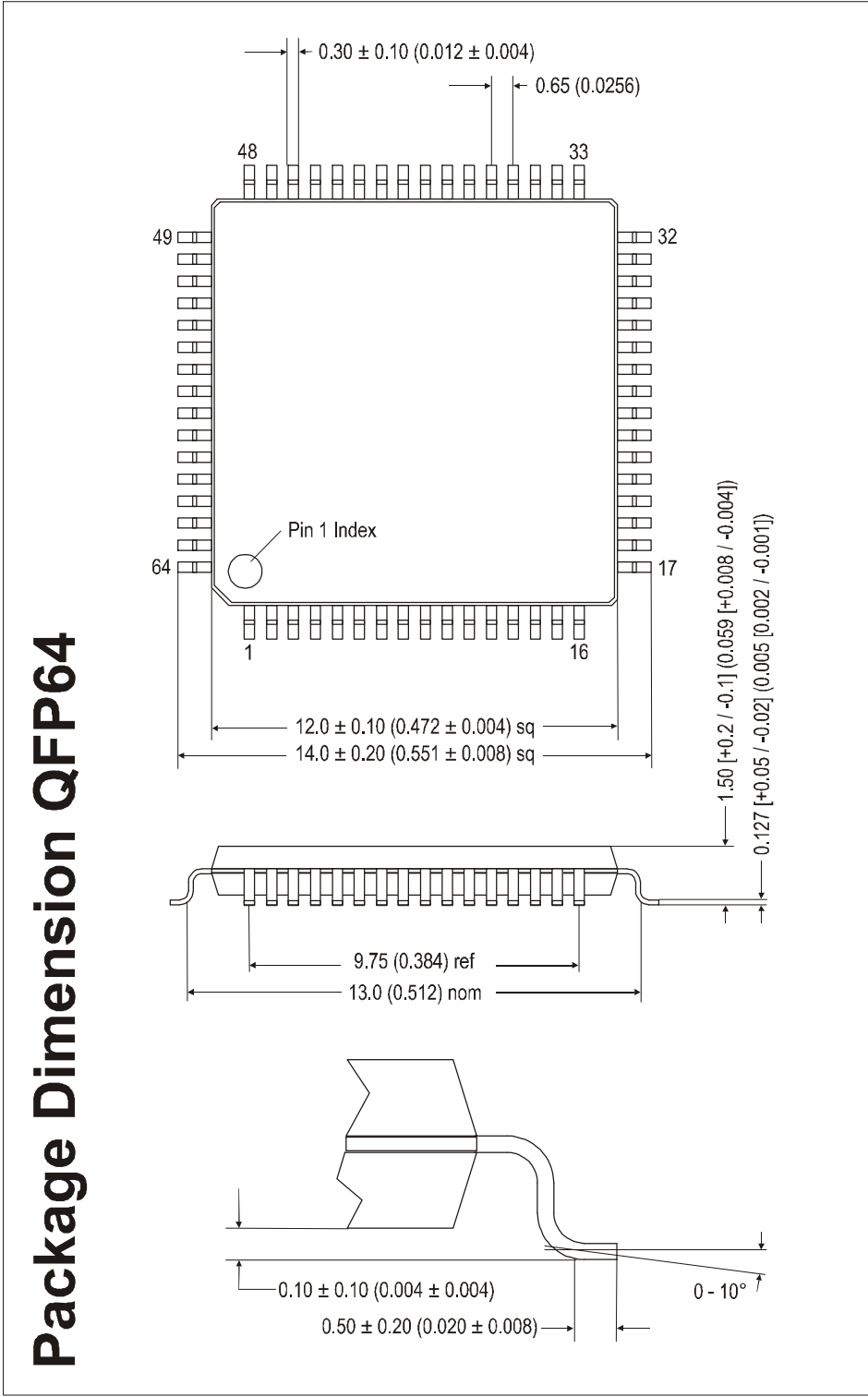

Typical Application: Joystick Board JOB04013

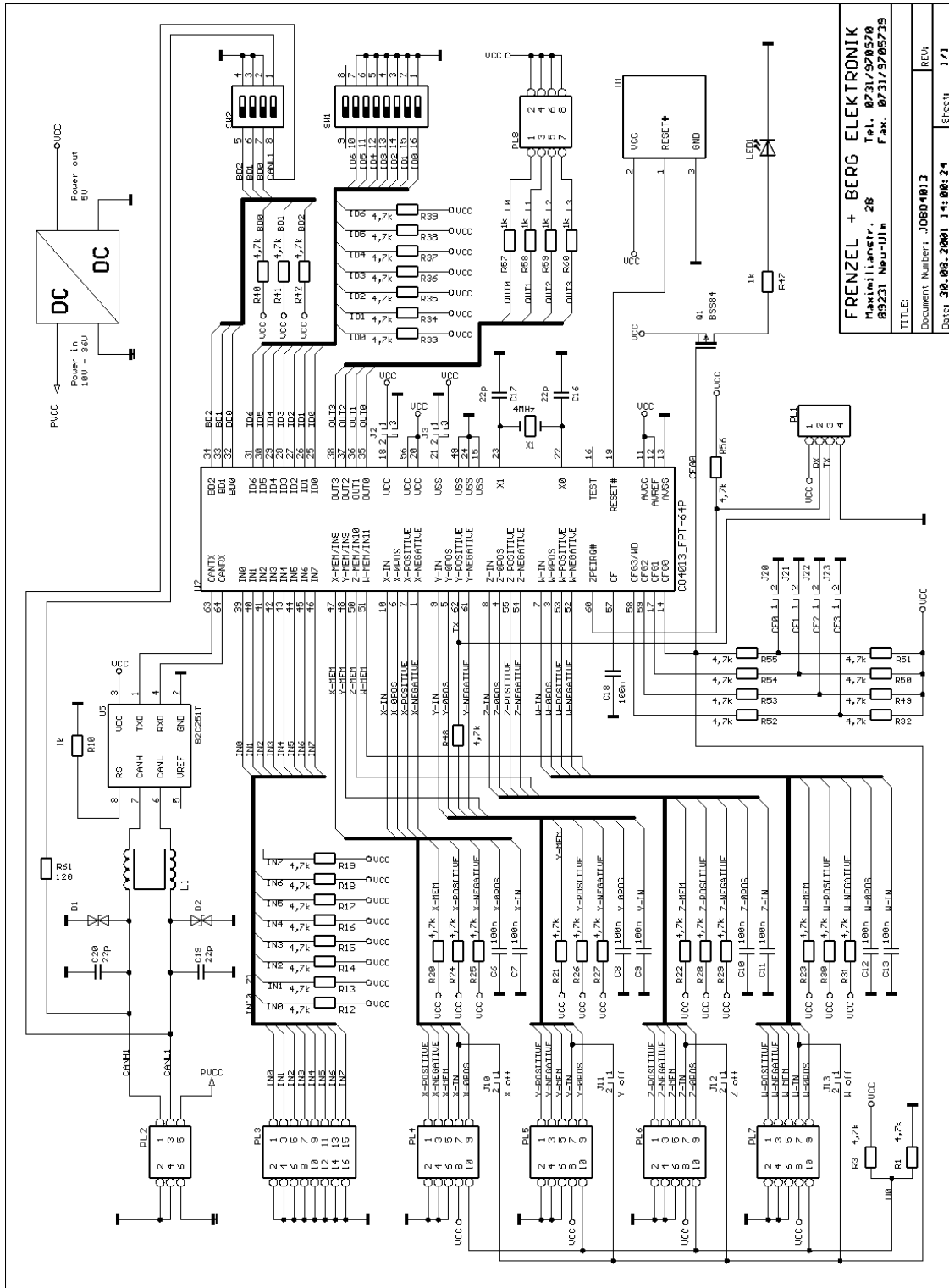

FRENZEL + BERG ELEKTRONIK
 Mainli Str. 28
 89231 Neu-Ulm
 Tel. 0731/978578
 Fax. 0731/9785739

TITLE:
 Document Number: JOB04013
 Date: 30.08.2001 14:00:24
 Sheet: 1/1

Typical Application: Eva-Board CO4013-EVA

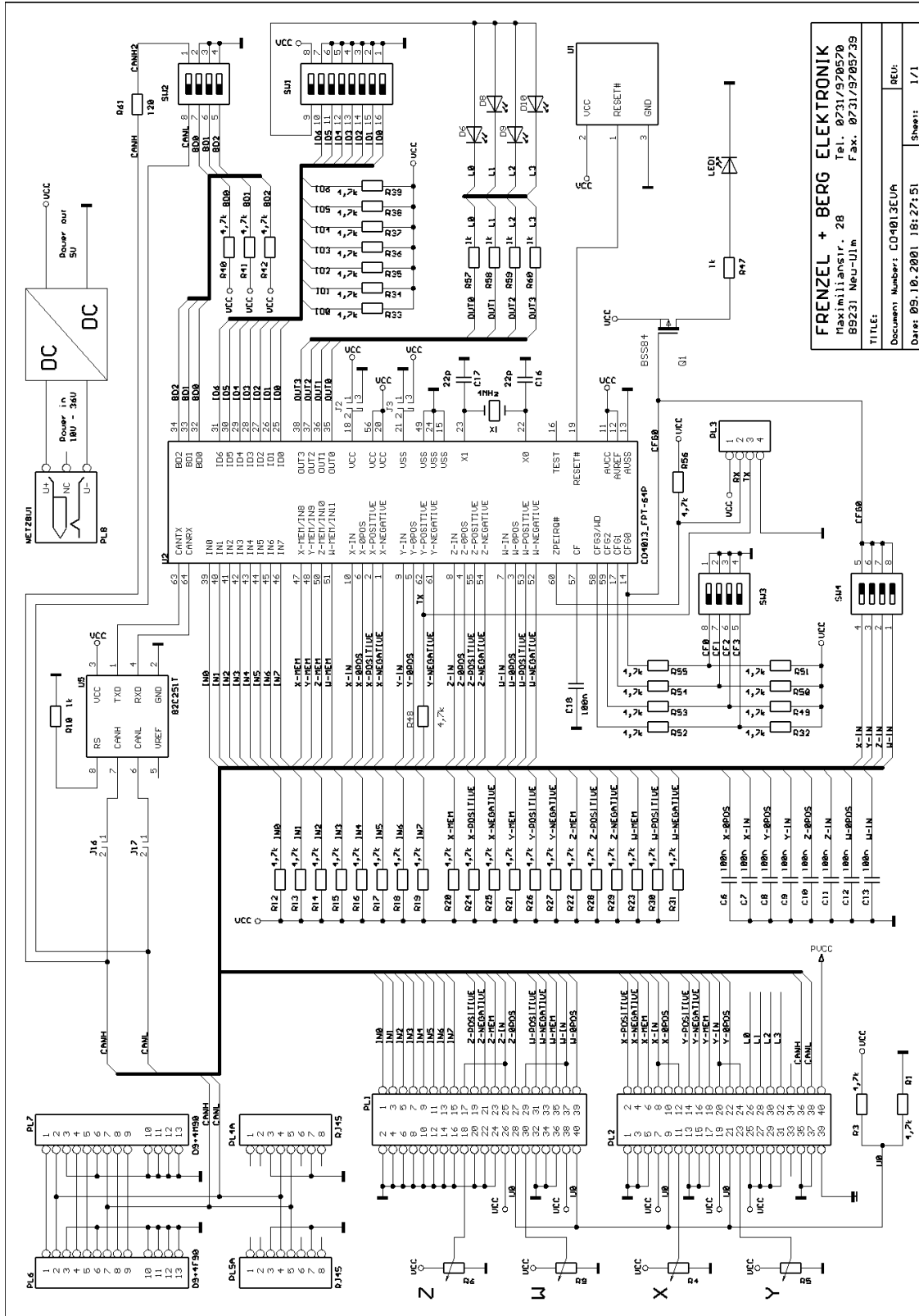

FRENZEL + BERG ELEKTRONIK
 Maximilianstr. 28
 89231 Neu-Ulm
 Tel. 0731/970570
 Fax. 0731/9705739

TITLE:
 Document Number: CO4013EVA
 Date: 09.10.2001 18:27:51
 Sheet: 1/1

| | | | |
|--|-----------|---|-----------|
| General Description | 1 | Index 1001 : Error Register | 10 |
| Features | 1 | Index 1002 : Status Register | 11 |
| CANopen Features | 1 | Index 1005 : COB-ID Sync | 11 |
| Ordering Information | 1 | Index 1008 : Device Name | 11 |
| Pin Assignment | 2 | Index 1009 : Hardware Version | 11 |
| Pin Listing | 2 | Index 100C : Guard Time | 11 |
| Pin Listing continued | 2 | Index 100D : Life Time Factor | 12 |
| Pin Description | 3 | Index 100E : COB-ID Guard | 12 |
| X-IN .. W-IN: Analog Axis Position Input pins | 3 | Index 1010 : Store Parameters..... | 12 |
| X-0POS .. W-0POS: Analog Axis Zero Position Input pins | 3 | Index 1011 : Restore Default Parameters | 13 |
| X..W-NEGATIVE / X..W-POSITIVE | 3 | Index 1014 : COB-ID Emergency | 13 |
| X-MEM .. W-MEM: Memory function | 3 | Index 1015 : Inhibit Time Emergency | 14 |
| OUT0 .. OUT3..... | 3 | Index 1017 : Producer Heartbeat Time | 14 |
| IN0 to IN7: General purpose digital input pins | 3 | Index 1018 : Identity Object..... | 14 |
| CF: Filter Capacitor input..... | 3 | Index 2000 : Device Manufacturer..... | 15 |
| X0, X1: Crystal oscillator input | 3 | Index 2101 : System Configuration | 15 |
| TEST: Reserved pin | 3 | Index 2180 : CAN Restart Time..... | 15 |
| ZPEIRQ#: Zero-Position Interrupt..... | 4 | DS301: PDO Parameter Objects | 15 |
| VCC, AVCC, VSS, AVSS, AVREF: Power Supply..... | 4 | Communication Parameter Objects..... | 15 |
| RES#: Reset input pin | 4 | PDO Mapping Objects..... | 17 |
| CFG0 to CFG3: Configuration input pins | 4 | DS401: Digital Input Objects | 18 |
| CFG0/LED: Configuration input / LED output | 4 | Index 5003 : Debounce Time Digital Input | 18 |
| CFG3/WD: Configuration input / watchdog output..... | 4 | Index 6000 : Read Digital Input 8 Bit..... | 18 |
| CANRX, CANTX: CAN interface pins | 4 | Index 6002 : Polarity Input 8 Bit..... | 19 |
| Handling the Device | 4 | Index 6005 : Global Interrupt Enable..... | 19 |
| Preventing latch up | 4 | Index 6006 : Interrupt Mask Any Change | 20 |
| Handling unused Pins..... | 4 | Index 6007/8 : Interrupt Mask on Edge | 20 |
| Power Supply Pins..... | 4 | DS401: Digital Output Objects | 20 |
| Power Supply for A/D converter..... | 5 | Index 6200 : Write to Digital Output..... | 20 |
| Input / output pins | 5 | Index 6202 : Polarity Output 8 Bit..... | 21 |
| Pull up/down resistors..... | 5 | Index 6206 : Error Mode Output 8 Bit..... | 21 |
| In Circuit programming of MB90F497 | 5 | Index 6207 : Error Value Output 8 Bit..... | 22 |
| Device Configuration | 6 | DS401: Analog Input Objects | 22 |
| CAN Identifier | 6 | Index 5401 : Axis Zero Point Enlargement..... | 22 |
| Baud rate | 6 | Index 6401 : Joystick Position 16 Bit..... | 23 |
| Operation Mode: Nr of Supported axis | 6 | Index 6421 : Analog Input Interrupt Trigger..... | 23 |
| Operation Mode: Memory Function and I/O..... | 6 | Index 6423 : Analog Input Interrupt Enable | 23 |
| Operation Mode: CFG3 | 7 | Index 6424/5/6/7/8 : Analog Input Interrupt Limits.... | 24 |
| Object Dictionary | 7 | Index 6431 : Analog Input Offset | 24 |
| DS301: global Objects | 7 | Emergency Messages | 25 |
| DS301: PDO Parameter Objects | 8 | Mapping I/O to Object Dictionary | 26 |
| DS401: Digital Input Objects..... | 9 | Summary of operation modes | 26 |
| DS401: Digital Output Objects..... | 9 | I/O-Mapping in Mode 0 | 27 |
| DS401: Analog Input Objects..... | 9 | I/O-Mapping in Mode 1 | 27 |
| Description of Object Dictionary | 10 | I/O-Mapping in Mode 2 | 28 |
| Index 0005 | 10 | I/O-Mapping in Mode 3..... | 28 |
| Index 0006 | 10 | I/O-Mapping in Mode 4..... | 29 |
| Index 0007 | 10 | Absolute Maximum Ratings | 30 |
| DS301: Global Objects | 10 | Operation Conditions / Characteristics | 30 |
| Index 1000 : Device Type | 10 | Package Dimension CO4013A | 31 |
| | | Typical Application: Joystick Board JOBO4013 ... | 32 |
| | | Typical Application: Eva-Board CO4013-EVA | 33 |